

# TecsPak<sup>®</sup>

High performance thermoplastic  
co-polyester energy management  
bumpers

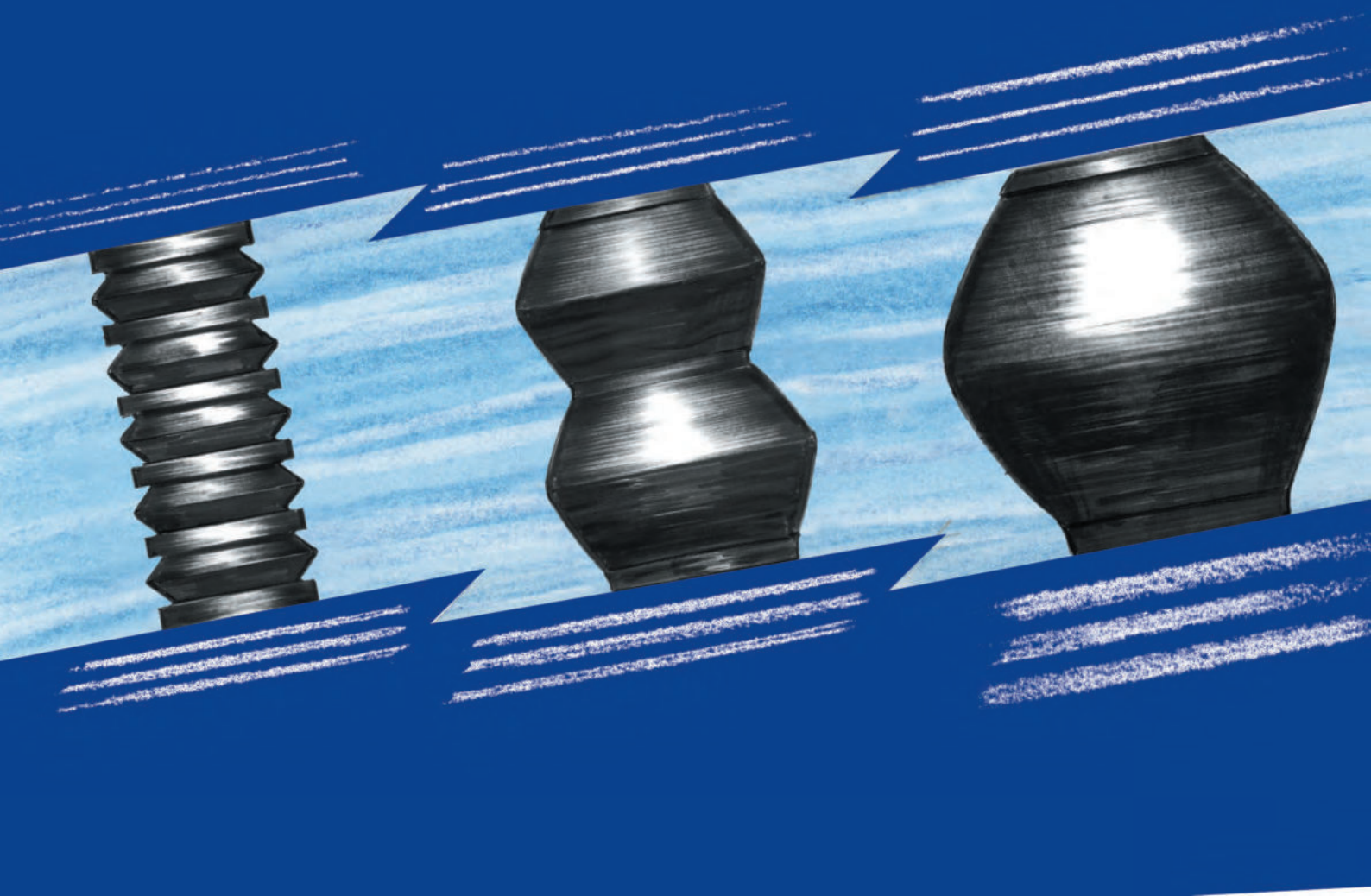

## General bumper and special bumpers

**TecsPak®** high performance bumpers made from a proprietary thermoplastic co-polyester which are light weight, strong and surpass conventional bumper systems (dampening systems).

**TecsPak®** dampening elements that find their home in applications having a difficult task of energy management.

**TecsPak®** dampening elements are based on unique designs along with a proprietary manufacturing process (with world wide patents). The morphology of the material is changed in order to achieve individual dampening characteristics.

Every element undergoes this special treatment and is processed to the required specifications.



TecsPak® as General bumpers

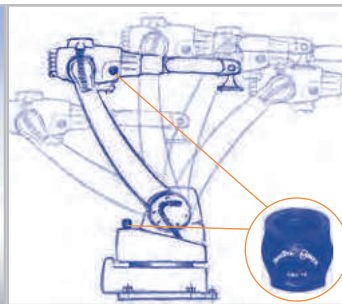

TecsPak® as a General bumper on a robotic arm acting as a stop

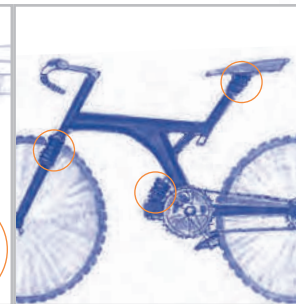

TecsPak® on a mountain bike suspension, both front and rear

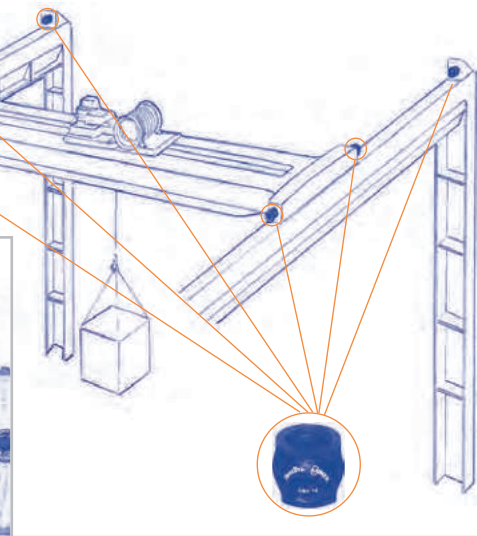

TecsPak® as a General bumper on an overhead crane, acting as a travel stop

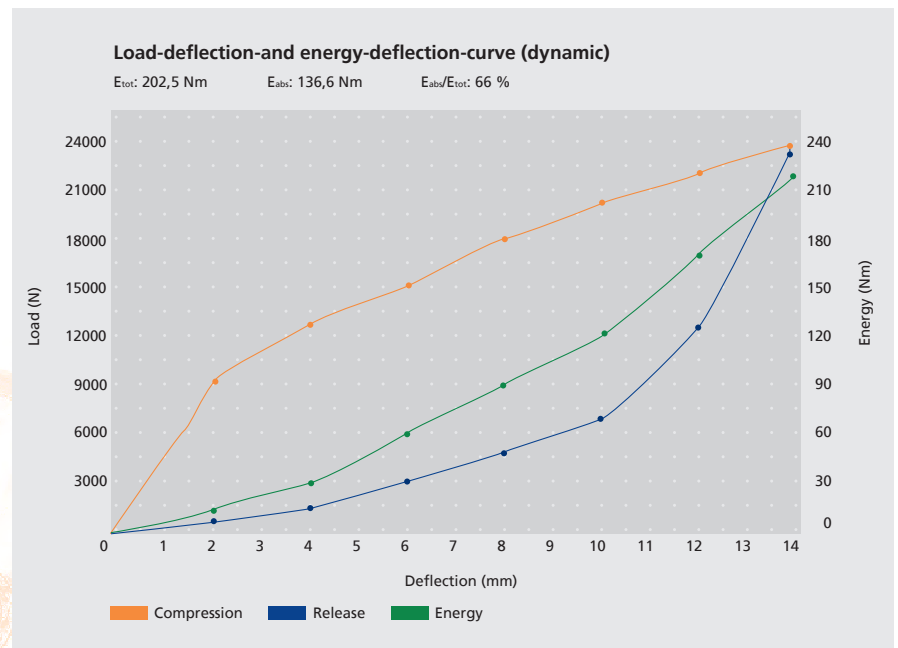

Load-deflection curve of a General bumper

## High performance dampening elements

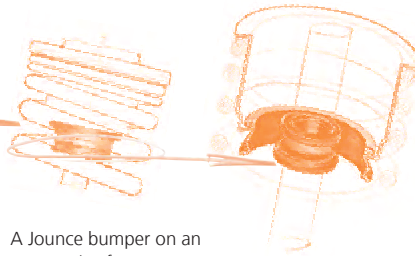
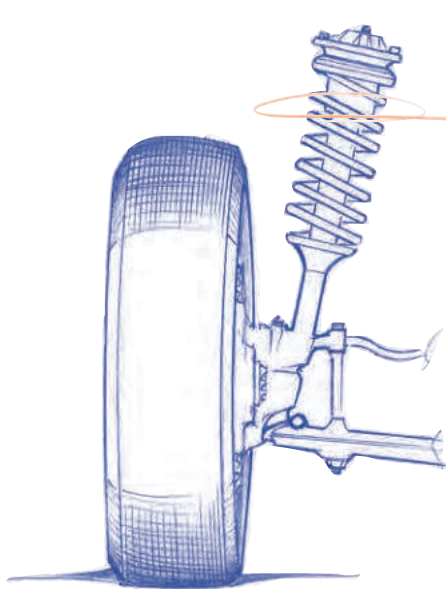

A Jounce bumper on an automotive front strut application

**TecsPak®** high performance elements are made from a special Co-polyester elastomer. They are used to absorb critical applied energies and are excellently suited to solve problems that involve high dynamic loads and where excellent dampening characteristics are required.

### Specialty designed bumpers



Compact sized rebound bumper for automotive suspensions



Rebound stop, automotive



Rebound stop, truck

**TecsPak®** bumpers work best in compression and withstand extreme loads. In comparison to other materials, such as rubber, urethanes and even steel springs; TecsPak® can absorb far more energy per weight and volume than its closest competitor.

Significant improvements can be achieved when compared to dampening elements made from rubber, polyurethane and steel. Life expectancy is extremely high; up to twenty times longer than for urethane bumpers, up to ten times longer than rubber bumpers and up to five times longer than steel springs.

**TecsPak®** bumpers can replace conventional materials in a multitude of applications. Thus one can achieve significant weight, volume, and cost reductions.

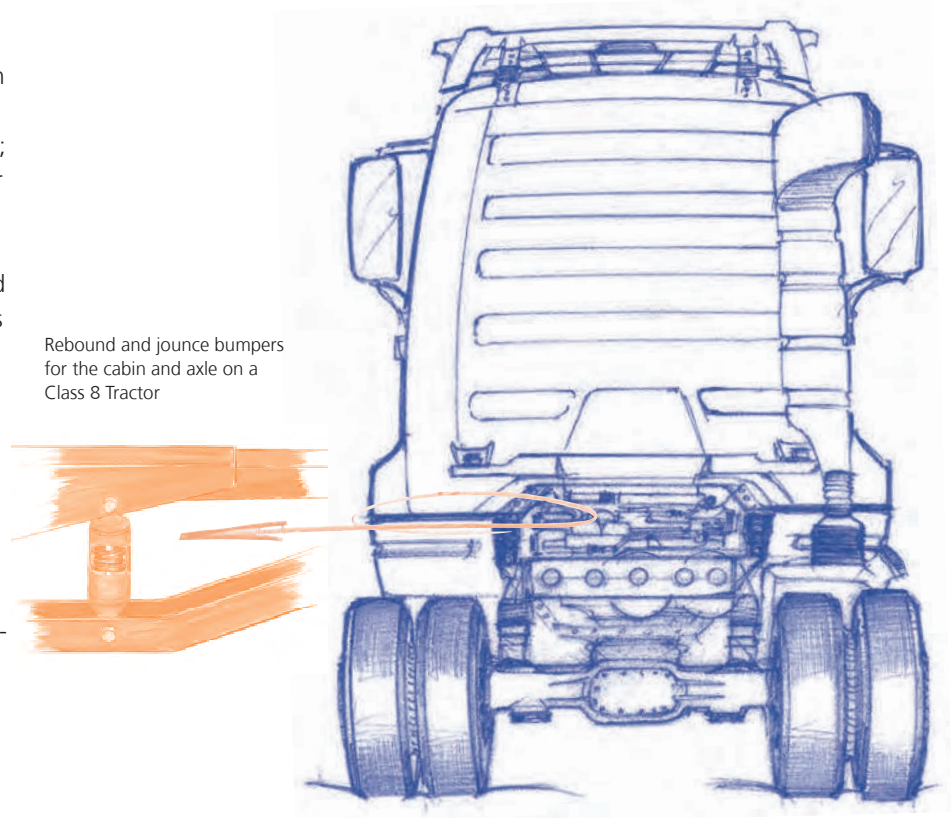

Rebound and jounce bumpers for the cabin and axle on a Class 8 Tractor

## Standard General bumpers

**TecsPak®** general bumpers are standard shelf items. Available in six different versions containing more than eighty different sized elements. (Please refer to the General Bumper catalog for more details).

**GBR Series:** Radial loaded bumper, for dynamic forces between 0.3 - 6.2 kN. The softest of the TecsPak® General bumpers with the longest travel. Energy absorption between 17 - 35 %.

**GBA-S Series:** Axial loaded bumper, for dynamic forces between 1.3 - 24 kN. Energy absorption 26 - 56 %.

**GBA-Series:** Also an Axial loaded bumper, for dynamic forces between 3.1 - 82 kN. Energy absorption 40 - 66 %.

**TCB Series:** Axial loaded bumper, for dynamic forces between 80 - 978 kN. Energy absorption 31 - 63 %.

**Tube bumpers:** Radial loaded bumper, for dynamic forces between 0.4-176 kN. Designed for forces distributed over a wide and or flat surface. (Please refer to the General bumper catalog for more details).

**Sucker-rod cushions:** A special TecsPak® General bumper for oil well pump heads.

Standard General bumpers



GBR7

GBA-107S

GBA2

TCB5

Radial Tube bumper, RTB 1-6

### TecsPak® General bumpers offer advantages:

- No tooling costs
- Short lead-time
- Available in small quantities

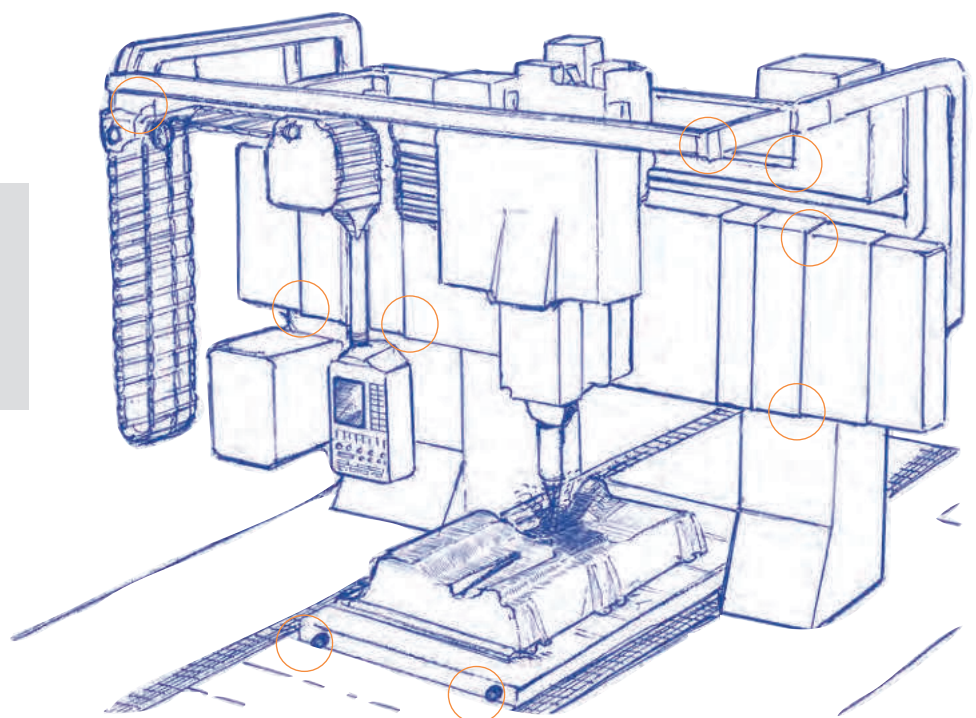

Dampening Elements for stroke limiters on traversing automated processing machines

## Custom designed bumpers

TecsPak® special bumpers can also be custom designed:

- Custom specifications for a given application.
- Close engineering support from design through production

- Rigorous laboratory and field-testing.
- Comprehensive QC according to QS 9000, ISO 9001 and VDA 6.1.

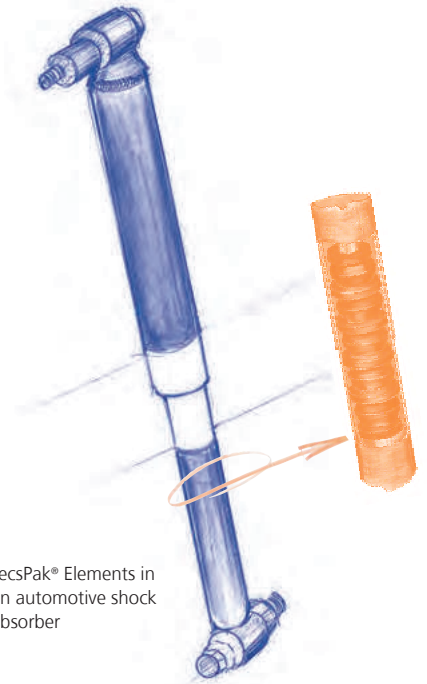

TecsPak® Elements in an automotive shock absorber

### Standard General bumpers



Conveyor belt bumper/mountain bike front fork bumper

Rebound stop, automotive bike front fork bumper

mountain bike rear suspension; ready to install

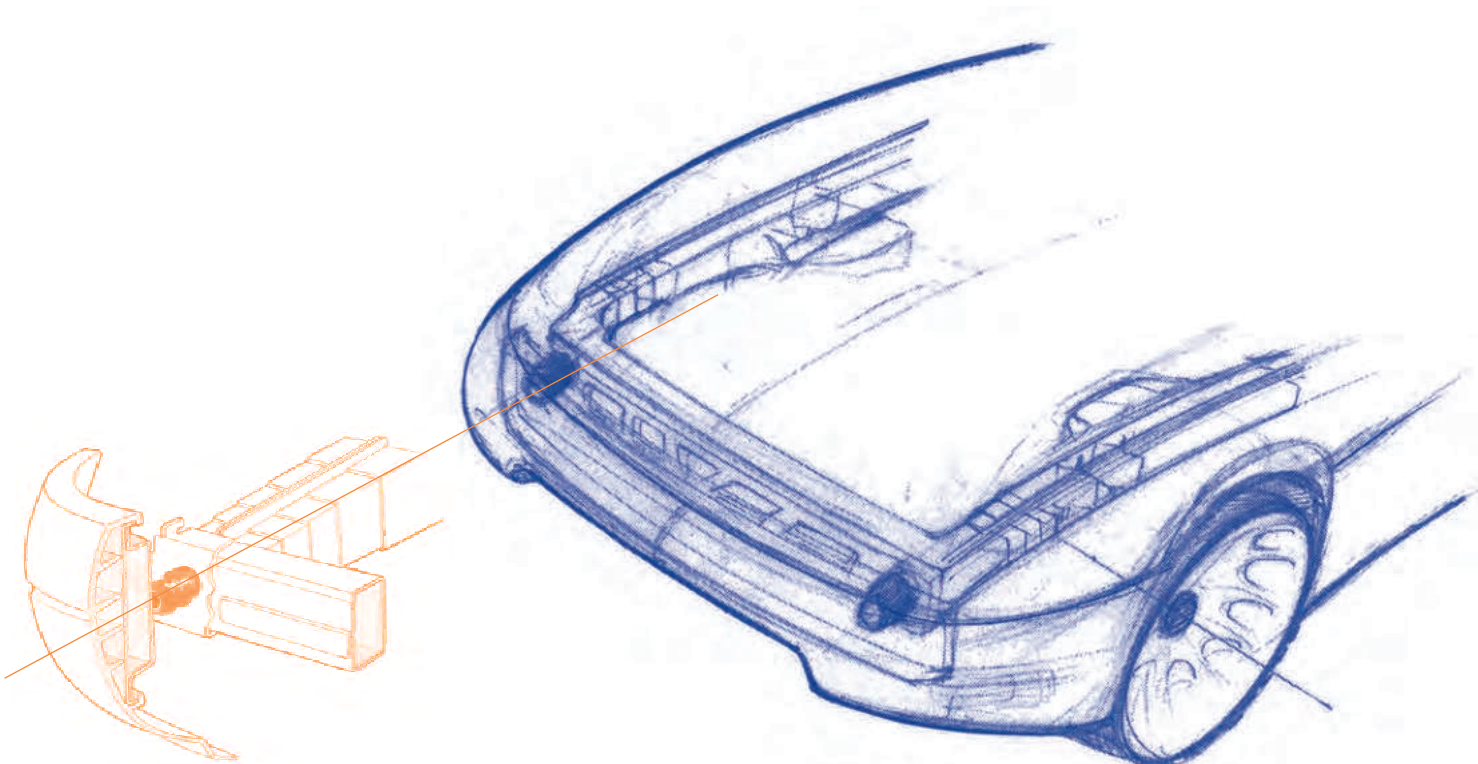

5 mph frontal impact cushion

## TecsPak® – simply unbeatable

**TecsPak®** high performance bumpers offer significant advantages compared to conventional systems:

- Extreme long life expectancy
- Space saving design
- Low weight
- No water absorption
- No swelling
- Saltwater resistant
- No disintegration under extreme conditions
- Almost unlimited design possibilities
- Existing systems can be adapted quickly
- Excellent chemical resistance
- Resistant against micro organisms
- Excellent UV and Ozone resistance
- Service temperature from -40 F to +267 F

**TecsPak®** high performance bumpers are characterized by exceptional long life expectancy, optimum elasticity without failure. Proof for the universal problem solving capability of these bumper elements:

- Millions of bumpers used in today's automobiles and trucks
- Heavy duty truck applications under extreme conditions
- Used over decades as rail car draft gear bumpers
- Used in more than three million bicycles, stairsteppers, treadmills, and other fitness stations
- Used successfully in forklift truck and mast applications for many years

### **TecsPak® in Comparison**

- 20x more durable than urethane
- 10x more durable than rubber
- 5x more than steel coil springs
- Inert to chemicals, greases & oils
- Excellent notch insensitive
- Not Dry Rot, doesn't burst or falls apart
- Repeatable & Scalable



TecsPak® reliably dampens extreme loads and energies

**TecsPak® high performance bumper elements have been successfully used in millions of applications. They simplify design, increase life expectancy and reduce maintenance costs.**

**Please feel free to request additional, detailed information or contact our sales department at:**

**MöllerMiner GmbH**  
Am-Möller-Werk 1  
D-33129 Delbrück,  
Phone: +49 (0) 5250 9851-0  
Fax: +49 (0) 5250 9851-29  
Email: [claus.kirchner@moellergroup.com](mailto:claus.kirchner@moellergroup.com)  
[www.moellergroup.com](http://www.moellergroup.com)

MöllerMiner GmbH is a Joint Venture of the MöllerGroup GmbH, Bielefeld and the Miner Elastomer Products Corporation, Geneva, Illinois, USA.